



Technical Data

Specification & Capacities

SPX1280-2B
SPX1280-HYB



18,5kW / 35HP



18 kW + 13 kW



4,9-17,7m



8000kg



EN 13000

[m] [kg]

SPX1280 - OVERALL DIMENSIONS

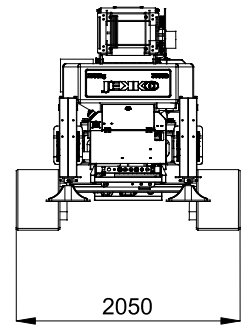
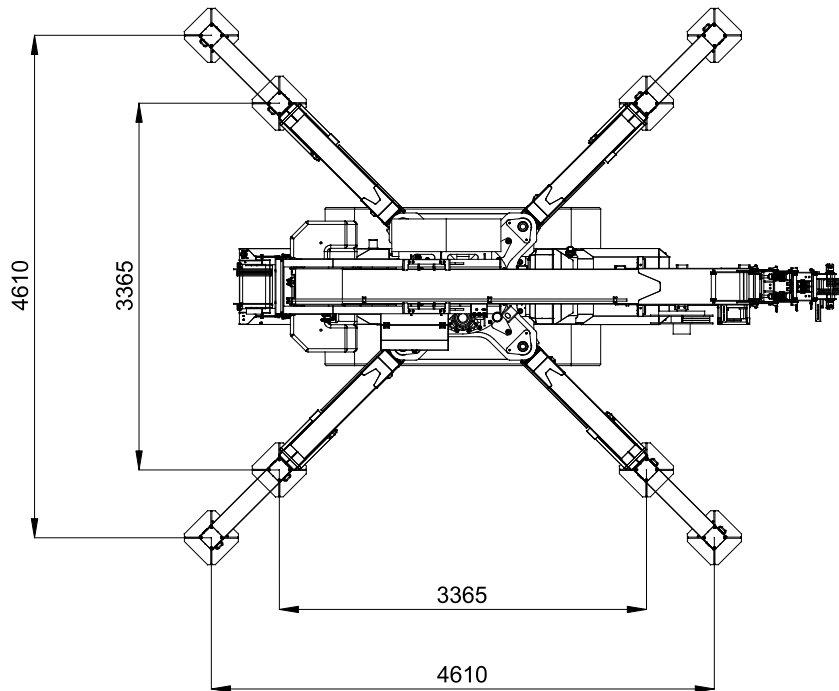
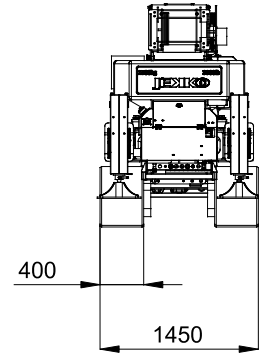
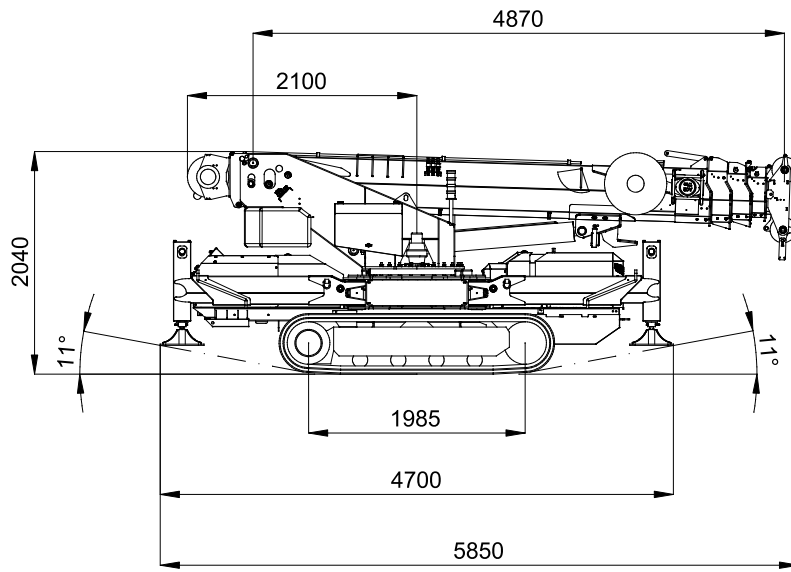

WEIGHTS		Name / version	kg ¹
		2B	6900
		HYB	6950
		2B & HYB	1500
		SINGLE FALL	42
		MULTIPLE FALL	110
		PP400-11D.V*	140
		3500G	70
		1500.1FL	265
		1500.3HL	675
		300GR	245
		HA-SPX1280	40
		WUK-04	3

*: Only for 2B version
¹: Dry weight
²: Engine working limit
³: Static lifting





ENGINE (2B ONLY)		KUBOTA V1505-E4B	
		18,5kW / 25HP	
		DIESEL	
		L	24
HYBRID		KUBOTA D1105-E4B	
		18,5kW / 25HP	
		DIESEL	
		L	24
		48V 300Ah	
		48V-3F 13kW / 17,5HP	
HYDRAULIC		ISO 6743-4:HFDU with VG46 viscosity class	
		Working temp	<70°C
		L	105
MOVEMENTS		km/h	1,3 / 2,8
		20° (36%) ²	
		kg/cm ²	0,72
		kg	6800 ³
		0°/75°	
		s	35
		360°	
		rpm	1,0
		m	4,9 - 17,7
		s	40

HOIST PERFORMANCE	Winch	Layer	Max line pull	Standard rope speed	Highest rope speed
			kg	m/min	m/min
		1	2072 ¹	46,4	83,5
		2	1893 ¹	50,7	91,4
		3	1743 ¹	55,1	99,3
		4	1615 ¹	59,5	107,2
	5	1504 ¹	63,8	115,1	
	Rope	Wire rope	Ø	Total lenght	Max load
			mm	m	kg
		19x7 right lang lay Non rotating	10	125	9480
Hook block	Load	N° of		Block type	
	kg	Sheaves	Lines		
	8000	3	6	Multiple fall block	
	7500	3	5		
	6000	2	4		
	4500	2	3		
	3000	1	2		
	1500	-	1	Single fall block	

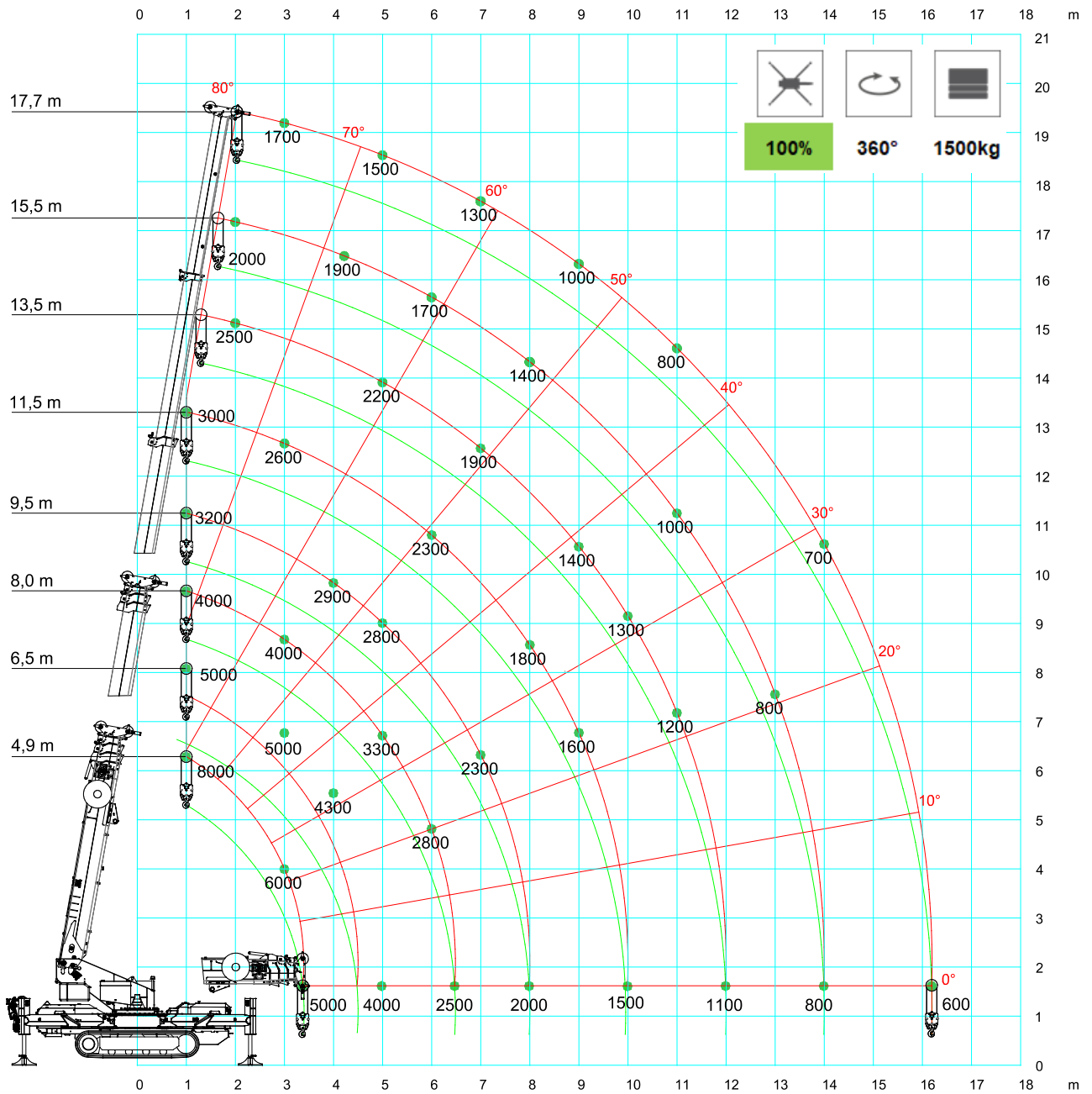



¹:LMI limited at 1500 kg

SPX1280 – MAIN BOOM







[m]													
[ton]	MAIN BOOM	100%	360°	1500kg									
	4,9	5,5	6,5	8,0	8,1	8,5	9,5	10,5	11,5	13,5	14,5	16,5	17,7
1,0	8,0	6,5	5,0	4,0	3,7	3,5	3,2						
2,0	8,0	6,5	5,0	4,0	3,7	3,4	3,2	3,0	2,8	2,5	2,3		
3,0	6,0	5,6	5,0	4,0	3,6	3,3	3,0	2,8	2,6	2,4	2,3	1,8	1,7
3,4	5,0	4,9	4,6	4,0	3,5	3,3	3,0	2,8	2,6	2,4	2,3	1,8	1,7
4,0		4,8	4,3	4,0	3,4	3,2	2,9	2,7	2,6	2,3	2,3	1,8	1,7
5,0			4,0	3,3	3,1	3,1	2,8	2,6	2,5	2,2	2,1	1,7	1,5
6,0				2,8	2,7	2,7	2,6	2,4	2,3	2,0	1,8	1,6	1,4
6,5				2,5	2,5	2,5	2,4	2,2	2,1	1,9	1,7	1,5	1,3
6,6					2,5	2,5	2,4	2,2	2,1	1,9	1,7	1,5	1,3
7,0						2,4	2,3	2,2	2,1	1,9	1,7	1,4	1,3
8,0							2,0	1,9	1,8	1,6	1,5	1,3	1,2
9,0								1,7	1,6	1,4	1,3	1,1	1,0
10,0									1,5	1,3	1,2	1,0	0,9
11,0										1,15	1,1	0,8	0,8
12,0										1,05	1,0	0,8	0,7
13,0											0,9	0,7	0,7
14,0												0,7	0,7
15,0												0,7	0,6
16,2													0,6





LC1280_V100_0519_MB_CW_1500_STAB_100

[m]													
[ton]	MAIN BOOM	50%	360°	1500kg									
	4,9	5,5	6,5	8,0	8,1	8,5	9,5	10,5	11,5	13,5	14,5	16,5	17,7
1,0	8,0	6,5	5,0	4,0	3,7	3,5	3,2						
2,0	7,0	6,0	5,0	4,0	3,7	3,4	3,2	3,0	2,8	2,5	2,3		
3,0	4,2	4,0	3,6	3,0	2,8	2,7	2,6	2,5	2,4	2,2	2,0	1,5	1,4
3,4	3,7	3,6	3,2	2,7	2,5	2,3	2,1	2,0	1,9	1,8	1,7	1,3	1,2
4,0		3,2	2,8	2,6	2,4	2,2	2,0	1,8	1,7	1,6	1,5	1,2	1,1
5,0			2,5	2,0	1,8	1,8	1,8	1,7	1,6	1,5	1,4	1,0	0,9
6,0				1,8	1,7	1,7	1,7	1,6	1,4	1,3	1,2	1,0	0,9
6,5				1,7	1,6	1,6	1,6	1,5	1,4	1,2	1,1	0,9	0,8
6,6					1,6	1,6	1,6	1,5	1,4	1,2	1,1	0,9	0,8
7,0						1,5	1,5	1,4	1,4	1,2	1,1	0,9	0,8
8,0							1,2	1,2	1,2	1,1	1,0	0,8	0,8
9,0								1,0	1,0	0,9	0,9	0,7	0,6
10,0									0,8	0,8	0,7	0,6	0,5
11,0										0,7	0,7	0,4	0,4
12,0										0,6	0,6	0,4	0,4
13,0											0,5	0,4	0,4
14,0											0,4	0,35	0,3
15,0												0,35	0,3
16,2													0,3

LC1280_V100_0519_MB_CW_1500_STAB_50

[m] / [ton]	 MAIN BOOM	 100%	 360°	 0kg	 EN								
	4,9	5,5	6,5	8,0	8,1	8,5	9,5	10,5	11,5	13,5	14,5	16,5	17,7
1,0	8,0	6,0	5,0	4,0	3,7	3,5	3,2						
2,0	8,0	6,0	5,0	4,0	3,7	3,4	3,2	3,0	2,8	2,5	2,3		
3,0	4,8	4,5	3,8	3,8	3,5	3,2	2,9	2,7	2,5	2,3	2,2	1,7	1,6
3,4	4,0	3,9	3,8	3,7	3,3	3,0	2,8	2,6	2,4	2,2	2,1	1,6	1,5
4,0		3,8	3,4	3,0	2,8	2,6	2,5	2,4	2,3	2,2	2,1	1,6	1,5
5,0			3,0	2,9	2,5	2,5	2,3	2,2	2,2	2,2	2,0	1,5	1,3
6,0				2,2	2,2	2,2	2,2	2,1	2,0	1,8	1,6	1,4	1,2
6,5				2,1	2,0	2,0	1,9	1,7	1,7	1,5	1,3	1,1	0,9
6,6					2,0	2,0	1,9	1,7	1,7	1,5	1,3	1,0	0,9
7,0						1,7	1,7	1,6	1,5	1,4	1,2	0,9	0,8
8,0							1,3	1,3	1,2	1,1	1,0	0,8	0,8
9,0								1,1	1,0	0,9	0,9	0,8	0,7
10,0									0,9	0,8	0,8	0,7	0,6
11,0										0,7	0,6	0,5	0,5
12,0										0,6	0,6	0,5	0,4
13,0											0,5	0,4	0,4
14,0												0,4	0,3
15,0												0,4	0,3
16,2													0,3





LC1280_V100_0519_MB_CW_0_STAB_100

[m] [ton]																
	MAIN BOOM	50%	360°	0kg	4,9	5,5	6,5	7,5	8	8,1	8,5	9,5	10,5	11,5	12,5	13,5
1,0	8,0	6,0	5,0	4,3	4,0	3,7	3,5	3,2								
2,0	7,0	6,0	5,0	4,3	4,0	3,7	3,4	3,2	3,0	2,6	2,4	2,4				
3,0	3,8	3,6	3,2	3,0	2,8	2,6	2,4	2,2	2,0	1,8	1,7	1,7				
3,4	3,0	3,0	2,9	2,6	2,5	2,4	2,2	2,0	1,8	1,6	1,4	1,4				
4,0		2,4	2,3	2,2	2,2	2,0	1,8	1,6	1,4	1,3	1,2	1,2				
5,0			1,7	1,6	1,6	1,5	1,5	1,5	1,4	1,3	1,2	1,2				
6,0				1,2	1,2	1,2	1,1	1,1	1,1	1,0	1,0	1,0				
6,5						1,1	1,1	1,0	1,0	1,0	1,0	0,9				
6,6							1,0	1,0	1,0	0,9	0,9	0,9				
7,0								0,9	0,9	0,8	0,8	0,7	0,7			
8,0									0,7	0,7	0,6	0,6	0,5			
9,0										0,6	0,5	0,5	0,5			
10,0											0,5	0,5	0,4			
11,0													0,4	0,4		
12,0																0,3

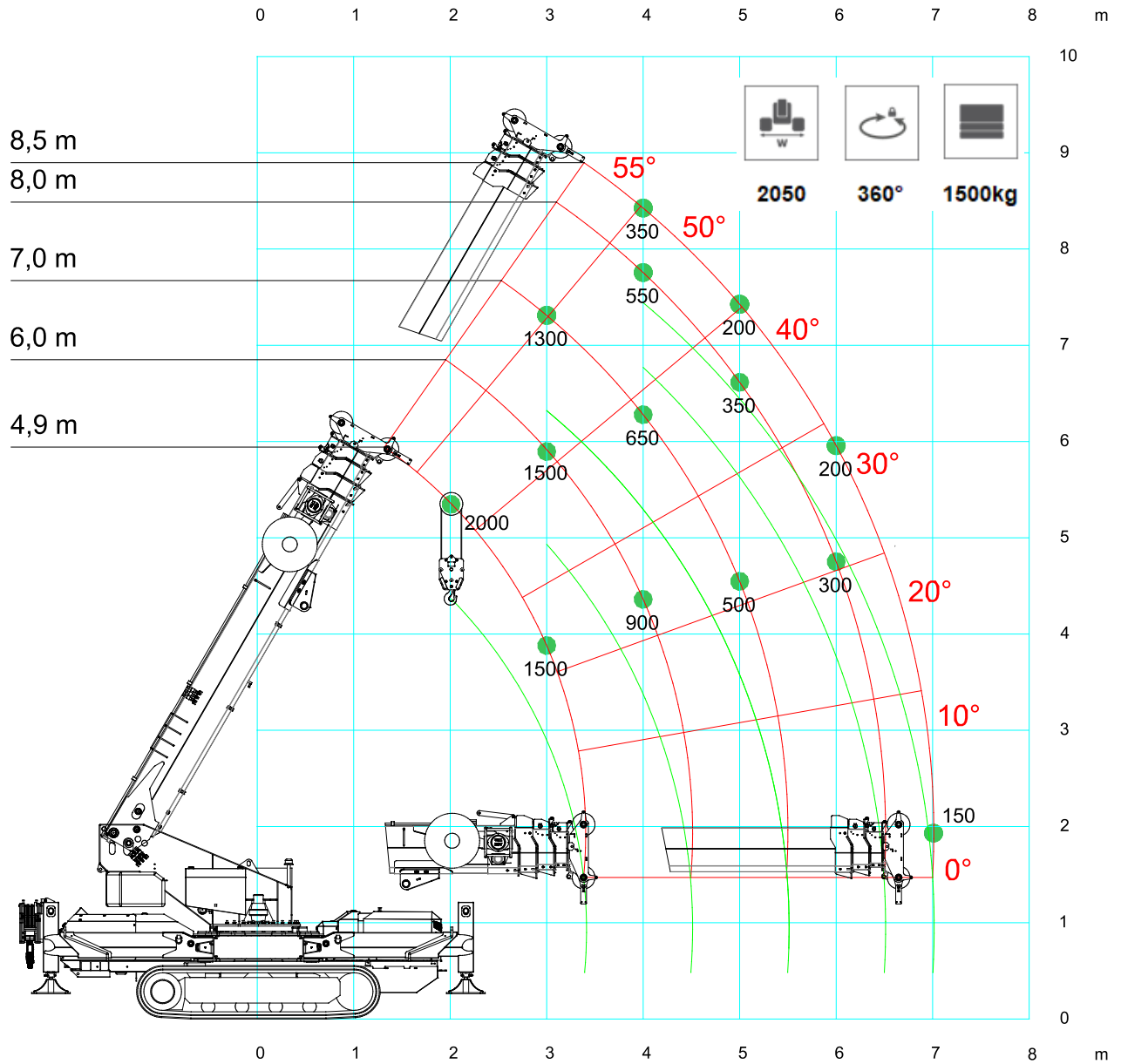



LC1280_V100_0519_MB_CW_0_STAB_50

SPX1280 – MAIN BOOM PICK & CARRY



[m] \ [ton]	 MAIN BOOM	 2050	>0km/h icon" data-bbox="465 155 525 195"/> >0km/h	 360°	 1500kg	EN
	4,9	5,5	6,5	7,5	8,5	
2,0	2,0	2,0	2,0	1,0	0,50	
3,0	1,5	1,5	1,3	0,75	0,45	
4,0		0,9	0,65	0,55	0,35	
5,0			0,5	0,35	0,2	
6,0				0,3	0,2	
7,1					0,15	

LC1280_V100_0519_MB_CW_1500_CINGOLI

[m] \ [ton]	 MAIN BOOM	 1450	>0km/h icon" data-bbox="465 510 525 550"/> >0km/h	 0°	 1500kg	EN
	4,9	5,5	6,5	7,5	8,5	
2,0	2,0	2,0	2,0	1,0	0,50	
3,0	1,5	1,5	1,3	0,75	0,45	
4,0		0,9	0,65	0,55	0,35	
5,0			0,5	0,35	0,2	
6,0				0,3	0,2	
7,1					0,15	





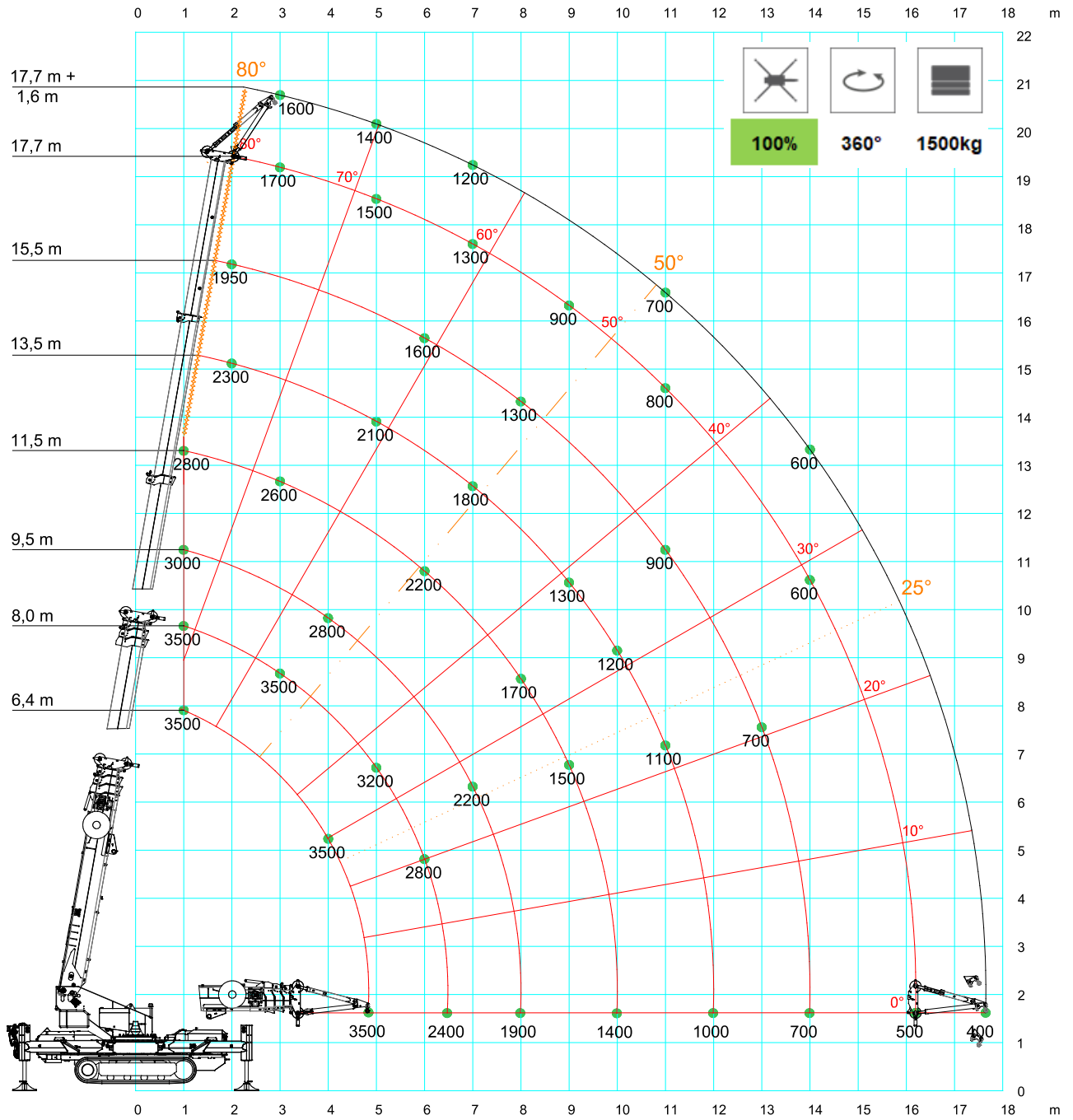

LC1280_V100_0519_MB_CW_1500_CINGOLI

SPX1280 + JIB3500G

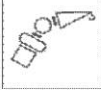





HOOK CONFIGURATION







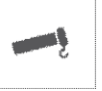

- 25°: max angle with jib in -33° hook configuration.
- . - . 50°: max angle with jib in -7° hook configuration.
- ***** 80°: max angle with jib in 22° hook configuration.

[m]								
[ton]	JIB3500G	100%	360°	1500kg	HOOK			
	6,4	8,0	9,5	11,5	13,5	15,5	17,7	19,3
1,0	3,5	3,5	3,0	2,8				
2,0	3,5	2,5	2,9	2,6	2,3	1,95	1,8	1,6
3,0	3,5	3,5	2,9	2,6	2,2	1,9	1,7	1,6
4,0	3,5	3,4	2,8	2,5	2,15	1,8	1,6	1,5
5,0		3,2	2,6	2,35	2,1	1,7	1,5	1,4
6,0		2,8	2,4	2,2	2,0	1,6	1,4	1,3
7,0			2,2	2,1	1,8	1,45	1,3	1,2
8,0			1,9	1,7	1,5	1,3	1,1	1,0
9,0				1,5	1,3	1,1	0,9	0,8
10,0				1,4	1,2	1,0	0,8	0,75
11,0					1,1	0,9	0,8	0,7
12,0					1,0	0,8	0,7	0,65
13,0						0,7	0,65	0,65
14,0						0,7	0,6	0,6
15,0							0,6	0,55
16,0							0,5	0,45
17,0								0,43
17,7								0,4

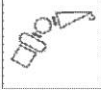





LC1280_V100_0519_RUNNER_7deg_CW1500_G_STAB_100

[m]								
[ton]	JIB3500G	50%	360°	1500kg	HOOK			
	6,4	8,0	9,5	11,5	13,5	15,5	17,7	19,3
1,0	3,5	3,5	3,0	2,8				
2,0	3,2	3,2	2,9	2,6	2,3	1,20	1,1	1,0
3,0	1,8	1,6	1,5	1,4	1,2	1,1	0,95	0,9
4,0	1,7	1,6	1,4	1,25	1,00	0,9	0,85	0,8
5,0		1,6	1,3	1,2	0,95	0,85	0,8	0,75
6,0		1,5	1,3	1,1	0,9	0,8	0,75	0,7
7,0			1,2	1,0	0,85	0,75	0,7	0,65
8,0			1,0	0,8	0,75	0,6	0,55	0,5
9,0				0,7	0,6	0,52	0,46	0,4
10,0				0,6	0,58	0,5	0,44	0,38
11,0					0,56	0,45	0,42	0,36
12,0					0,55	0,45	0,4	0,35
13,0						0,4	0,35	0,33
14,0						0,33	0,32	0,3
15,0							0,3	0,23
16,0							0,25	0,22
17,0								0,21
17,7								0,2

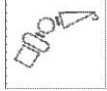
LC1280_V100_0519_RUNNER_7deg_CW1500_G_STAB_50

[m]								
[ton]	JIB3500G	100%	360°	0kg	HOOK			
	6,4	8,0	9,5	11,5	13,5	15,5	17,7	19,3
1,0	3,5	3,5	3,0	2,8				
2,0	3,5	3,5	2,9	2,5	2,0	1,5	1,4	1,3
3,0	3,2	3,0	2,8	2,3	1,8	1,4	1,3	1,2
4,0	2,5	2,3	2,0	1,8	1,6	1,35	1,2	1,1
5,0		2,2	1,8	1,60	1,4	1,3	1,1	1,0
6,0		2,0	1,6	1,4	1,2	1,1	1,0	0,9
7,0			1,5	1,3	1,1	1,00	0,9	0,8
8,0			1,3	1,1	1,0	0,9	0,8	0,7
9,0				1,0	0,9	0,8	0,7	0,6
10,0				0,9	0,8	0,7	0,6	0,55
11,0					0,7	0,65	0,6	0,5
12,0					0,6	0,55	0,5	0,45
13,0						0,5	0,45	0,4
14,0						0,5	0,4	0,35
15,0							0,35	0,3
16,0							0,26	0,24
17,0								0,22
17,7								0,2

LC1280_V100_0519_RUNNER_7deg_CW0_G_STAB_100

[m]						
[ton]	JIB3500G	50%	360°	0kg	HOOK	
	6,4	8,0	9,5	11,5	13,5	
1,0	3,5	3,5	3,0	2,8		
2,0	3,2	3,2	2,9	2,4	1,8	
3,0	1,8	1,7	1,6	1,5	1,4	
4,0	1,7	1,6	1,4	1,2	1,1	
5,0		1,4	1,3	1,2	1,0	
6,0		1,1	1,0	0,9	0,8	
7,0			0,8	0,7	0,6	
8,0			0,7	0,6	0,5	
9,0				0,5	0,4	
10,0				0,35	0,3	
11,0					0,25	
12,0					0,2	

LC1280_V100_0519_RUNNER_7deg_CW0_G_STAB_50

SPX1280+ JIB3500G

PULLEY CONFIGURATION

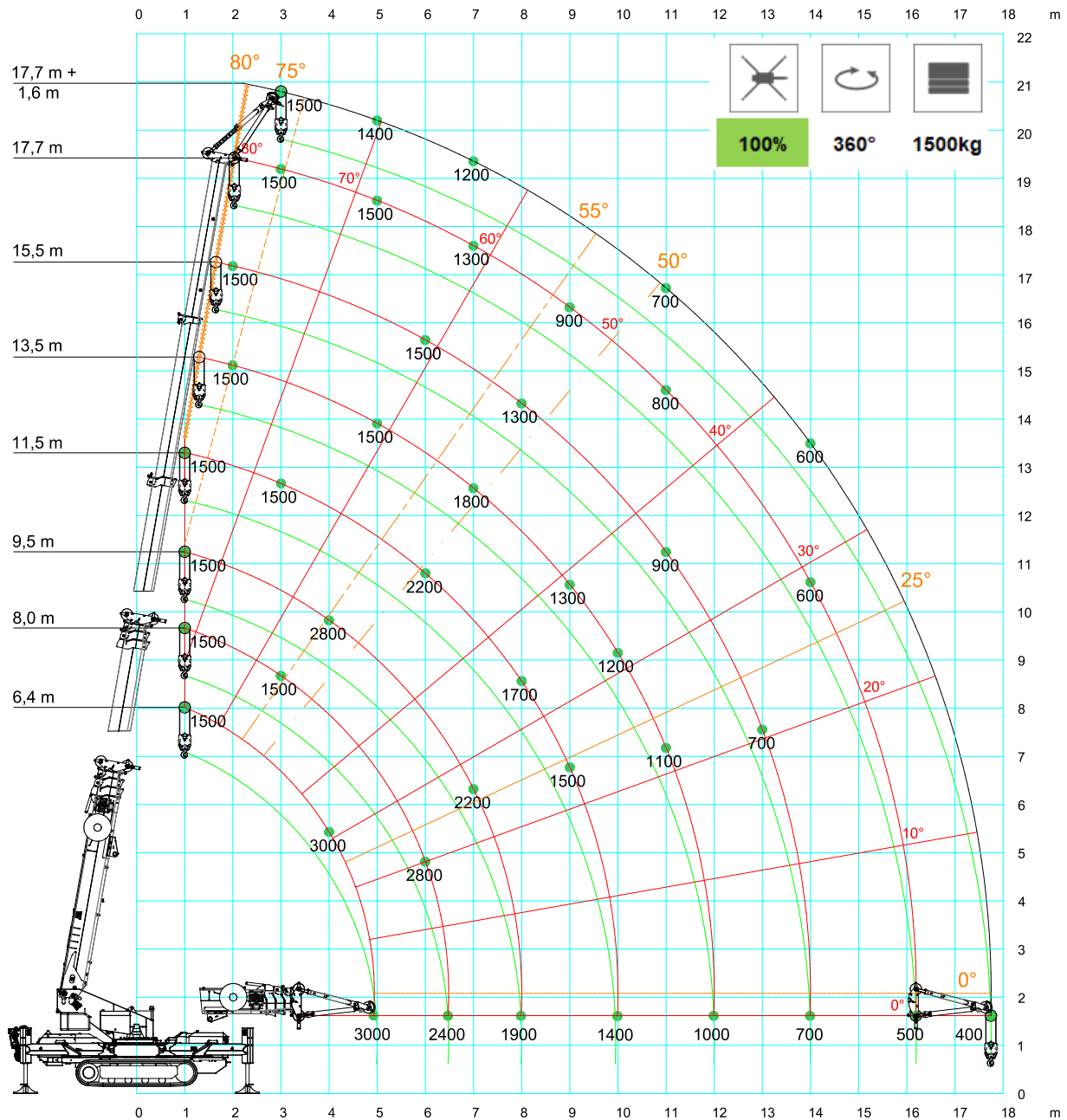

- 0°: max angle with jib in -33° double fall configuration, maximum 3000 kg.
- 25°: max angle with jib in -7° double fall configuration, maximum 3000 kg.
- . - . 50°: max angle with jib in -33° single fall configuration, maximum 1500 kg.
- - - - 55°: max angle with jib in 22° double fall configuration, maximum 3000 kg.
- - - - 75°: max angle with jib in -7° single fall configuration, maximum 1500 kg.
- ***** 80°: max angle with jib in 22° single fall configuration, maximum 1500 kg.

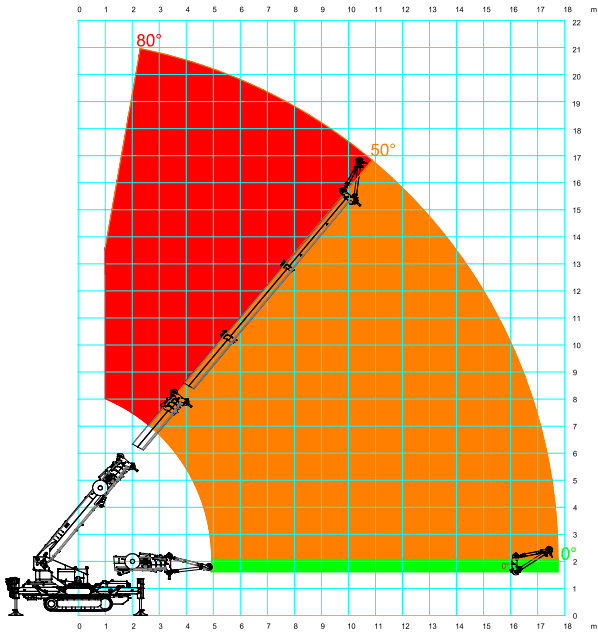

-33°



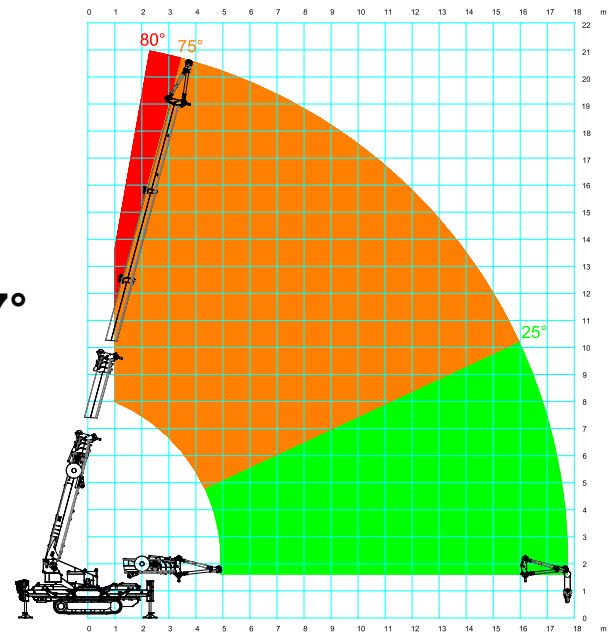

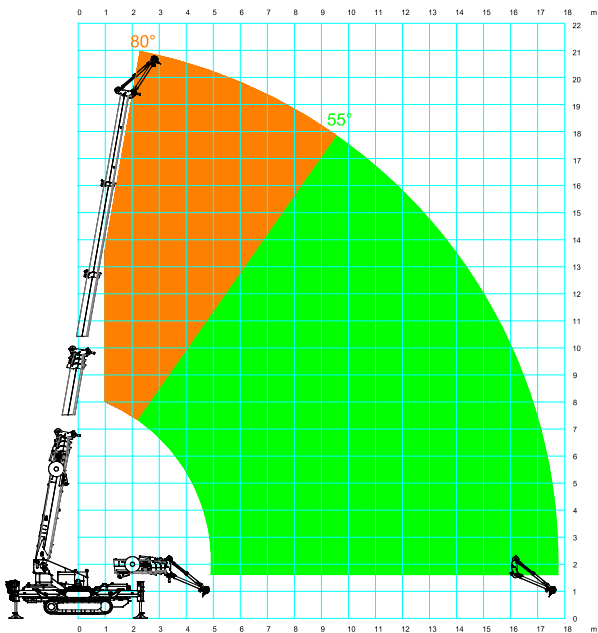

Movement capabilities:
■ : up to double fall area;
■ : single fall area;
■ : restricted area



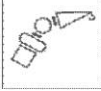





-7°







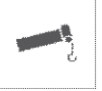

22°

[m]									
[ton]	JIB3500G	100%	360°	1500kg	PULLEY				
	6,4	8,0	9,5	11,5	13,5	15,5	17,7	19,3	
1,0	1,5	1,5	1,5	1,5					
2,0	1,5	1,5	1,5	1,5	1,5	1,5			
3,0	3,0	1,5	1,5	1,5	1,5	1,5	1,5	1,5	1,5
4,0	3,0	3,0	2,8	1,5	1,5	1,5	1,5	1,5	1,5
5,0		3,0	2,6	1,5	1,5	1,5	1,5	1,5	1,4
6,0		2,8	2,4	2,2	1,5	1,5	1,4	1,3	
7,0			2,2	2,1	1,8	1,45	1,3	1,2	
8,0			1,9	1,7	1,5	1,3	1,1	1,0	
9,0				1,5	1,3	1,1	0,9	0,8	
10,0				1,4	1,2	1,0	0,8	0,75	
11,0					1,1	0,9	0,8	0,7	
12,0					1,0	0,8	0,7	0,65	
13,0						0,7	0,65	0,65	
14,0						0,7	0,6	0,6	
15,0							0,6	0,55	
16,0							0,5	0,45	
17,0								0,43	
17,7								0,4	







LC1280_V100_0519_RUNNER_7deg_CW1500_STAB_100

[m]								
[ton]	JIB3500G	50%	360°	1500kg	PULLEY			
	6,4	8,0	9,5	11,5	13,5	15,5	17,7	19,3
1,0	1,5	1,5	1,5	1,5				
2,0	1,5	1,5	1,5	1,5	1,5	1,2	1,1	1,0
3,0	1,8	1,5	1,5	1,4	12,0	1,1	0,95	0,9
4,0	1,7	1,6	1,4	1,25	1,0	0,9	0,85	0,8
5,0		1,6	1,3	1,2	0,95	0,85	0,8	0,75
6,0		1,5	1,3	1,1	0,9	0,8	0,75	0,7
7,0			1,2	1,0	0,85	0,75	0,7	0,65
8,0			1,0	0,8	0,75	0,6	0,55	0,5
9,0				0,7	0,6	0,52	0,46	0,4
10,0				0,6	0,58	0,5	0,44	0,38
11,0					0,56	0,45	0,42	0,36
12,0					0,55	0,45	0,4	0,35
13,0						0,4	0,35	0,33
14,0						0,33	0,32	0,3
15,0							0,3	0,23
16,0							0,25	0,22
17,0								0,21
17,7								0,20

LC1280_V100_0519_RUNNER_7deg_CW1500_STAB_50

[m]								
[ton]	JIB3500G	100%	360°	0kg	PULLEY			
	6,4	8,0	9,5	11,5	13,5	15,5	17,7	19,3
1,0	1,5	1,5	1,5	1,5				
2,0	1,5	1,5	1,5	1,5	1,5	1,5	1,4	1,3
3,0	3,0	1,5	1,5	1,5	1,5	1,4	1,3	1,2
4,0	2,5	2,3	2,0	1,5	1,5	1,35	1,2	1,1
5,0		2,2	1,8	1,5	1,4	1,3	1,1	1,0
6,0		2,0	1,6	1,4	1,2	1,1	1,0	0,9
7,0			1,5	1,3	1,1	1,00	0,9	0,8
8,0			1,3	1,1	1,0	0,9	0,8	0,7
9,0				1,0	0,9	0,8	0,7	0,6
10,0				0,9	0,8	0,7	0,6	0,55
11,0					0,7	0,65	0,6	0,5
12,0					0,6	0,55	0,5	0,45
13,0						0,5	0,45	0,40
14,0						0,5	0,4	0,35
15,0							0,35	0,3
16,0							0,26	0,24
17,0								0,22
17,7								0,2





LC1280_V100_0519_RUNNER_7deg_CW1500_STAB_100

[m]						
[ton]	JIB3500G	50%	360°	0kg	PULLEY	
	6,4	8,0	9,5	11,5	13,5	
1,0	1,5	1,5	1,5	1,5		
2,0	1,5	1,5	1,5	1,5	1,5	
3,0	1,8	1,5	1,5	1,5	1,4	
4,0	1,7	1,6	1,4	1,20	1,1	
5,0		1,4	1,3	1,2	1,00	
6,0		1,1	1,0	0,9	0,8	
7,0			0,8	0,7	0,60	
8,0			0,7	0,6	0,50	
9,0				0,5	0,4	
10,0				0,4	0,30	
11,0					0,25	
12,0					0,20	

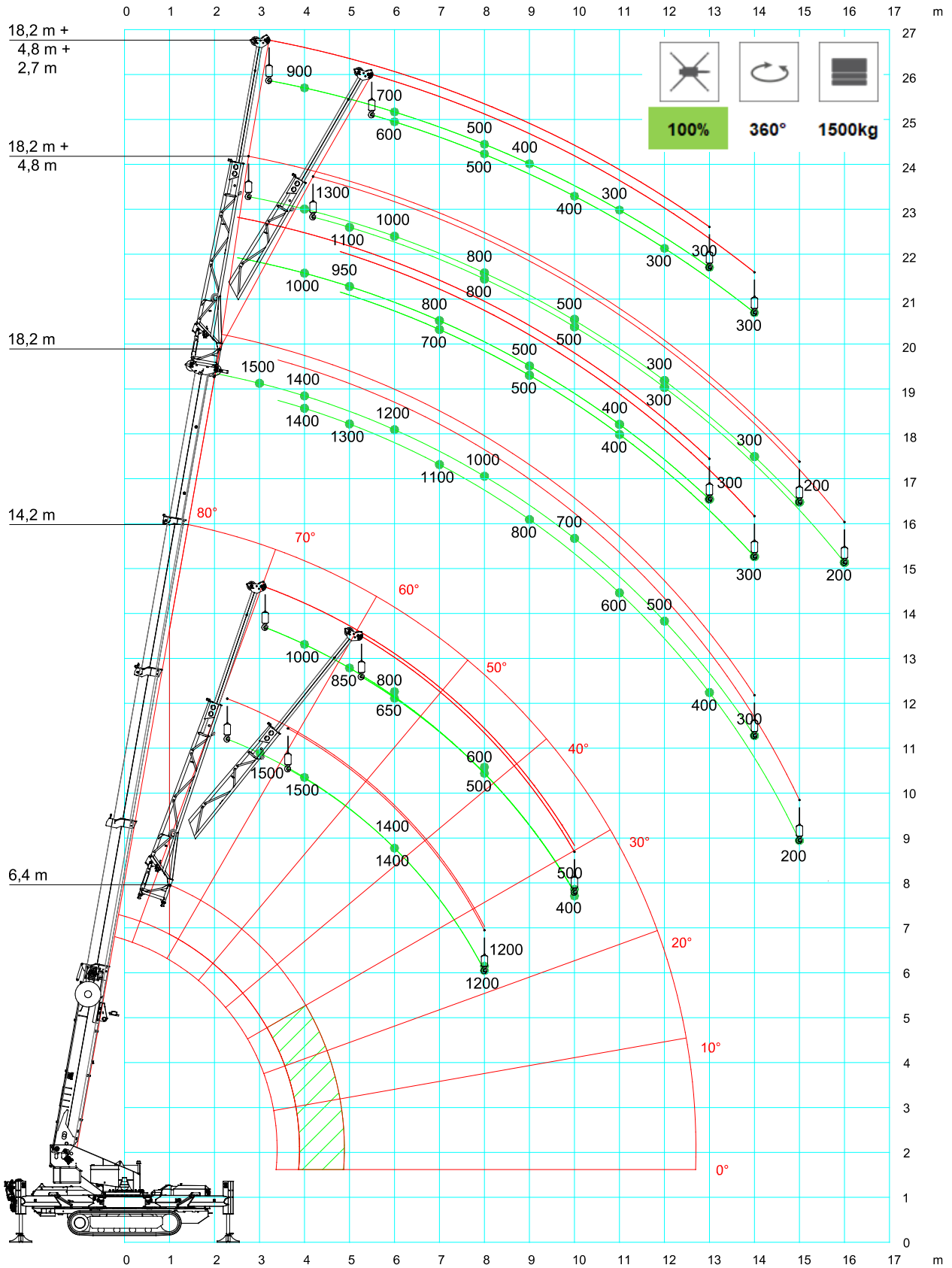

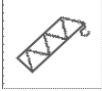

LC1280_V100_0519_RUNNER_7deg_CW0_STAB_50

SPX1280 + JIB1500.1FL

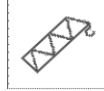

[m] [ton]						
	JIB1500.1F L	100%	360°	1500kg	EN	
	6,4 + 4,8		14,2 + 4,8		18,2 + 4,8	
	0°	25°	0°	25°	0°	25°
3,0	1,5		1,5			
4,0	1,5	1,5	1,4	1,4	1,3	
5,0	1,5	1,5	1,3	1,3	1,1	1,1
6,0	1,4	1,4	1,2	1,2	1,0	1,0
7,0	1,3	1,3	1,1	1,1	0,9	0,9
8,0	1,2	1,2	1,0	1,0	0,8	0,8
9,0			0,8	0,8	0,6	0,6
10,0			0,7	0,7	0,5	0,5
11,0			0,6	0,6	0,4	0,4
12,0			0,5	0,5	0,3	0,3
13,0			0,4	0,4	0,3	0,3
14,0			0,3	0,3	0,3	0,3
15,0				0,2	0,2	0,2
16,0						0,2

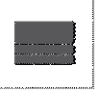
LC1280_V100_0519_JIB_0deg_STAB_100
 LC1280_V100_0519_JIB_25deg_STAB_100

[m] [ton]						
	JIB 1500.F L+ STINGER	100%	360°	1500kg	EN	
	6,4 + 4,8		14,2 + 4,8		18,2 + 4,8	
	0°	25°	0°	25°	0°	25°
4,0	1,0		1,0			
5,0	0,85		0,95		0,8	
6,0	0,8	0,65	0,9	0,8	0,7	0,6
7,0	0,65	0,55	0,8	0,7	0,6	0,6
8,0	0,6	0,5	0,6	0,6	0,5	0,5
9,0	0,55	0,45	0,5	0,5	0,4	0,4
10,0	0,5	0,4	0,5	0,5	0,4	0,4
11,0			0,4	0,4	0,3	0,3
12,0			0,3	0,3	0,3	0,3
13,0			0,3	0,3	0,3	0,3
14,0				0,3		0,3

LC1280_V100_0519_STINGER_0deg_STAB_100
 LC1280_V100_0519_STINGER_25deg_STAB_100



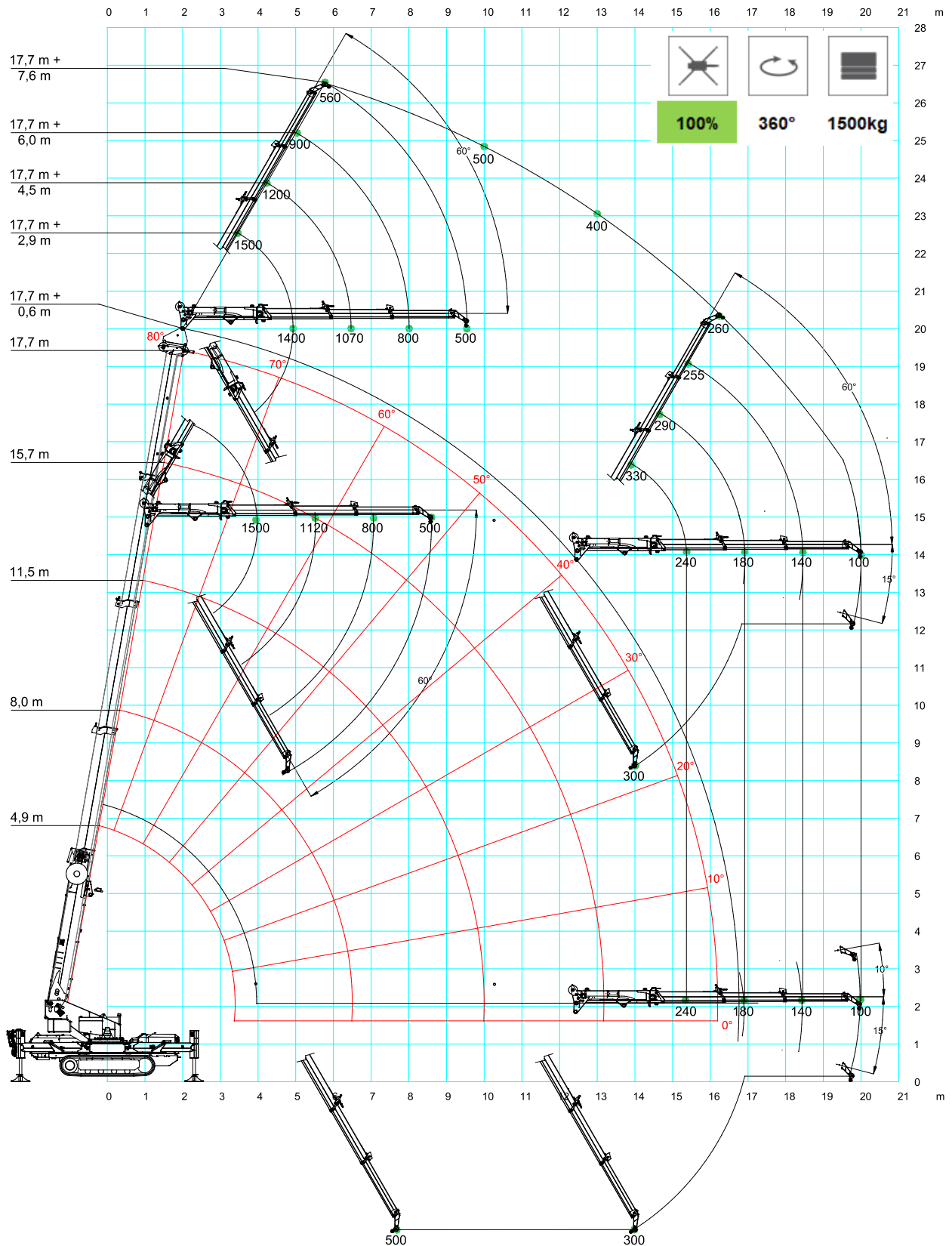

SPX1280 + JIB1500.3HL

HOOK CONFIGURATION

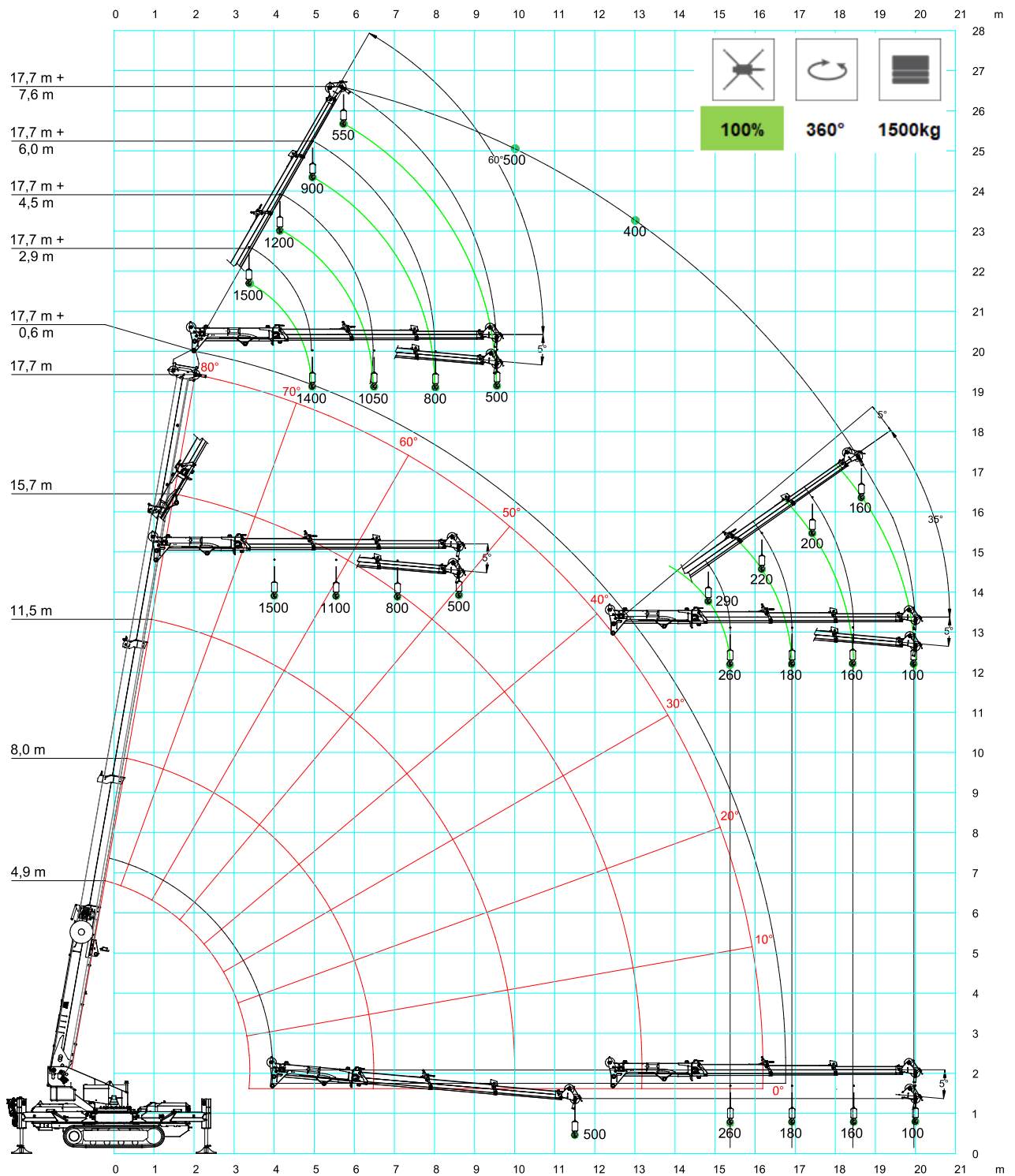

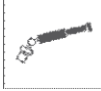

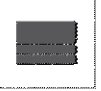

PULLEY CONFIGURATION

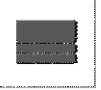

[m]					
[ton]	JIB1500.3HL	100%	360°	1500kg	
	2,93	4,47	6,01	7,55	
2,0	1,5				
3,0	1,5	1,2	0,95	0,65	
4,0	1,5	1,2	0,95	0,65	
5,0	1,4	1,2	0,9	0,6	
6,0	1,3	1,1	0,9	0,6	
7,0	1,2	1,1	0,8	0,5	
8,0	1,1	1,0	0,8	0,5	
9,0	1,0	0,9	0,8	0,5	
10,0	0,9	0,8	0,7	0,5	
11,0	0,8	0,7	0,60	0,50	
12,0	0,6	0,6	0,55	0,50	
13,0	0,5	0,4	0,4	0,4	
14,0	0,3	0,3	0,3	0,3	
15,0	0,3	0,3	0,3	0,3	
16,0	0,2	0,2	0,2	0,3	
17,0	0,1	0,2	0,2	0,2	
18,0		0,1	0,2	0,2	
19,0			0,1	0,1	
20,0				0,1	

LC1280_V100_0519_JIB1500_3H_CW_1500_STAB_100

[m]					
[ton]	JIB1500.3HL	50%	360°	1500kg	
	2,93	4,47	6,01	7,55	
2,0	1,5				
3,0	1,50	1,0	0,80	0,5	
4,0	1,4	1,00	0,8	0,5	
5,0	1,30	1,00	0,8	0,5	
6,0	1,0	1,0	0,8	0,5	
7,0	0,8	0,7	0,6	0,5	
8,0	0,6	0,55	0,5	0,45	
9,0	0,4	0,4	0,4	0,4	
10,0	0,25	0,25	0,25	0,3	
11,0	0,12	0,12	0,12	0,12	

LC1280_V100_0519_JIB1500_3H_CW_1500_STAB_50

SPX1280 + JIB300GR

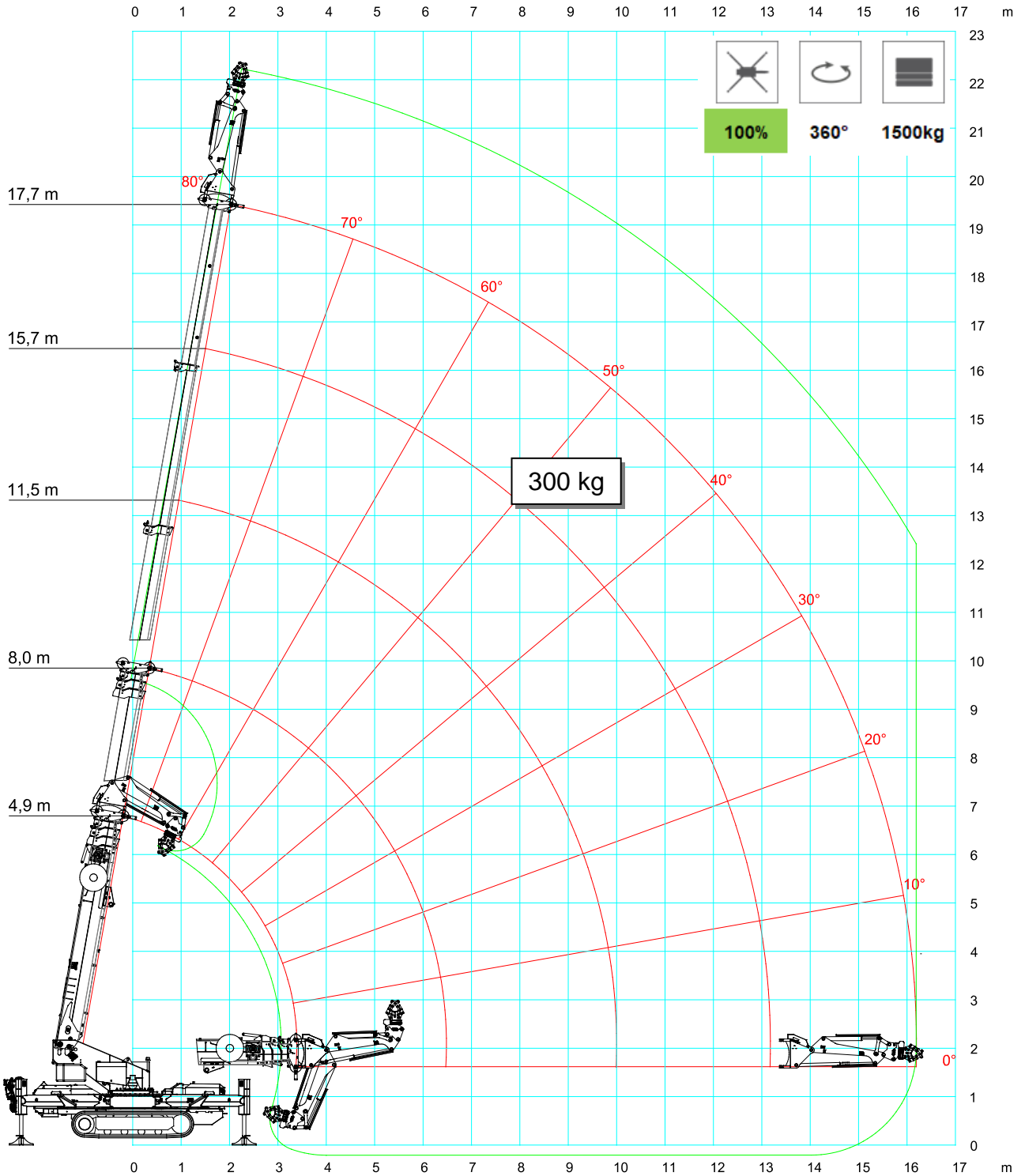

SPX1280 + JIB300GR

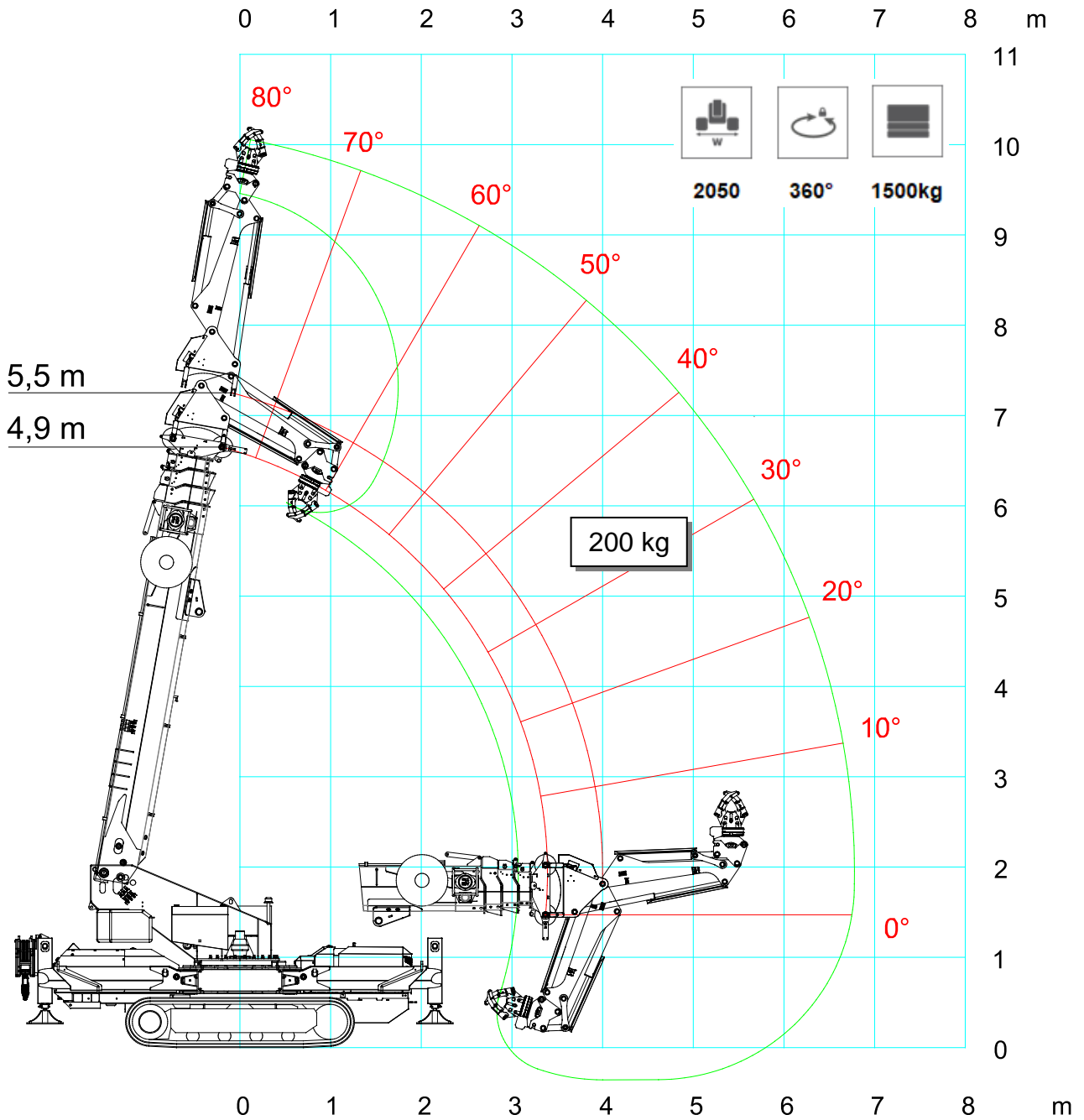

ACCESSORIES

ATTACHMENTS & TOOLS

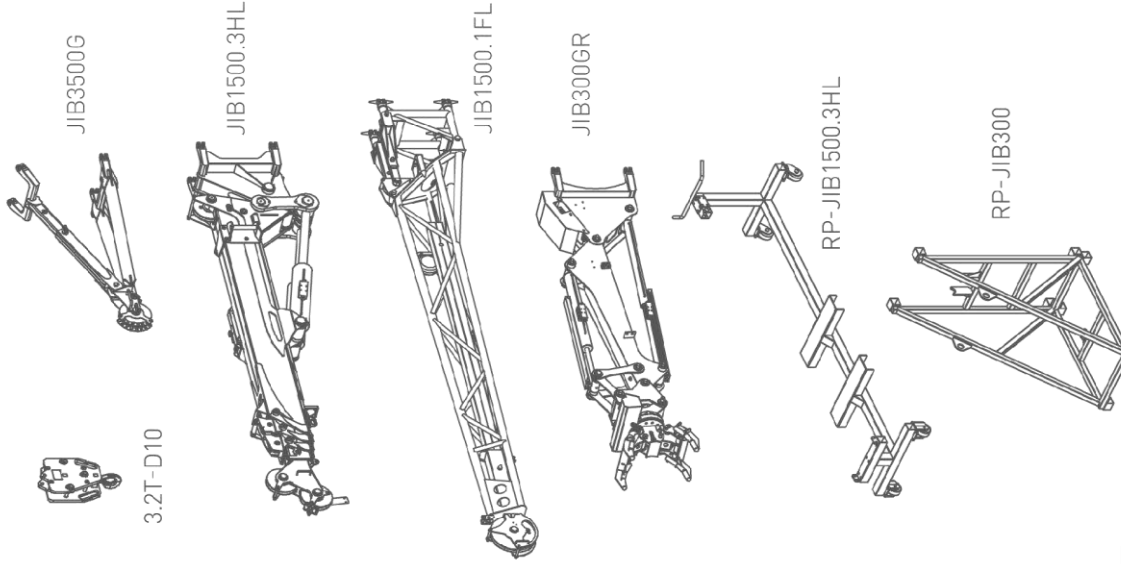

SPX1280-2B SPX1280-HYB

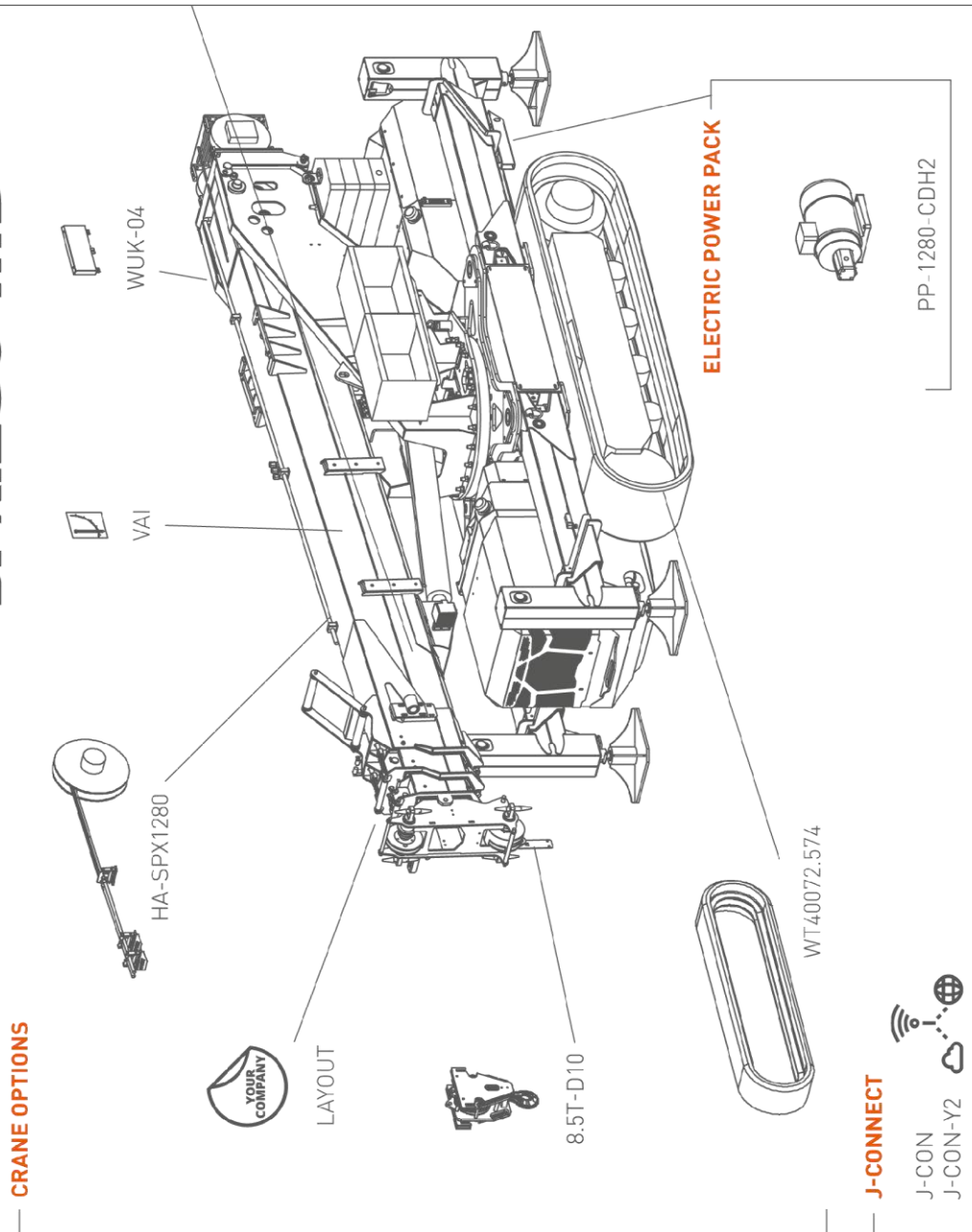

CRANE OPTIONS

J-CONNECT



CRANE COLOR

Boom & Covers

Chassis, Frames & Outriggers

STANDARD

RAL2004 RAL7021

RAL7021 RAL7021

PC02

RAL7021 RAL7021

RAL7021 RAL7021

PC12

RAL7021 RAL7021

RAL7021 RAL7021

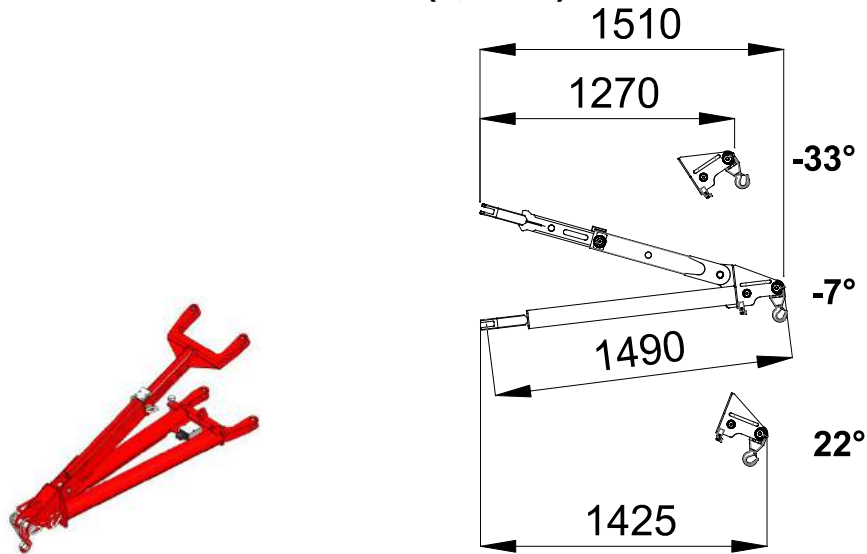
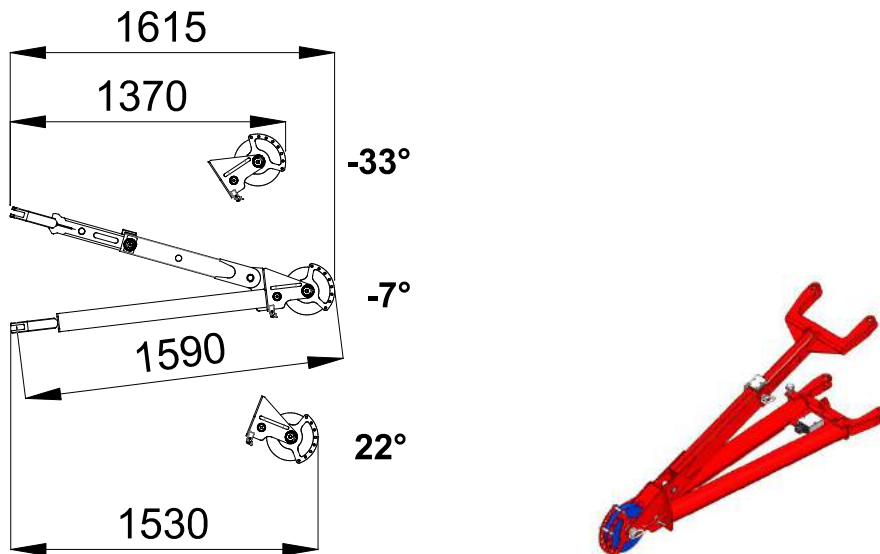
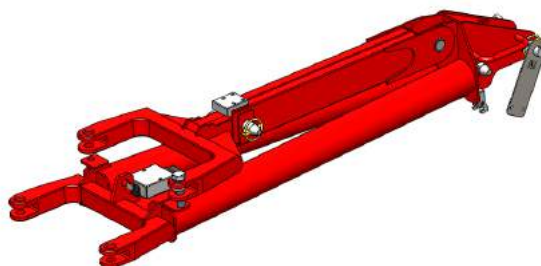

ACCESSORIES FEATURES**JIB3500G****HOOK (3,5Ton)****PULLEY (3Ton)****OUT SERVICE CONFIGURATION**

JIB1500.1FL

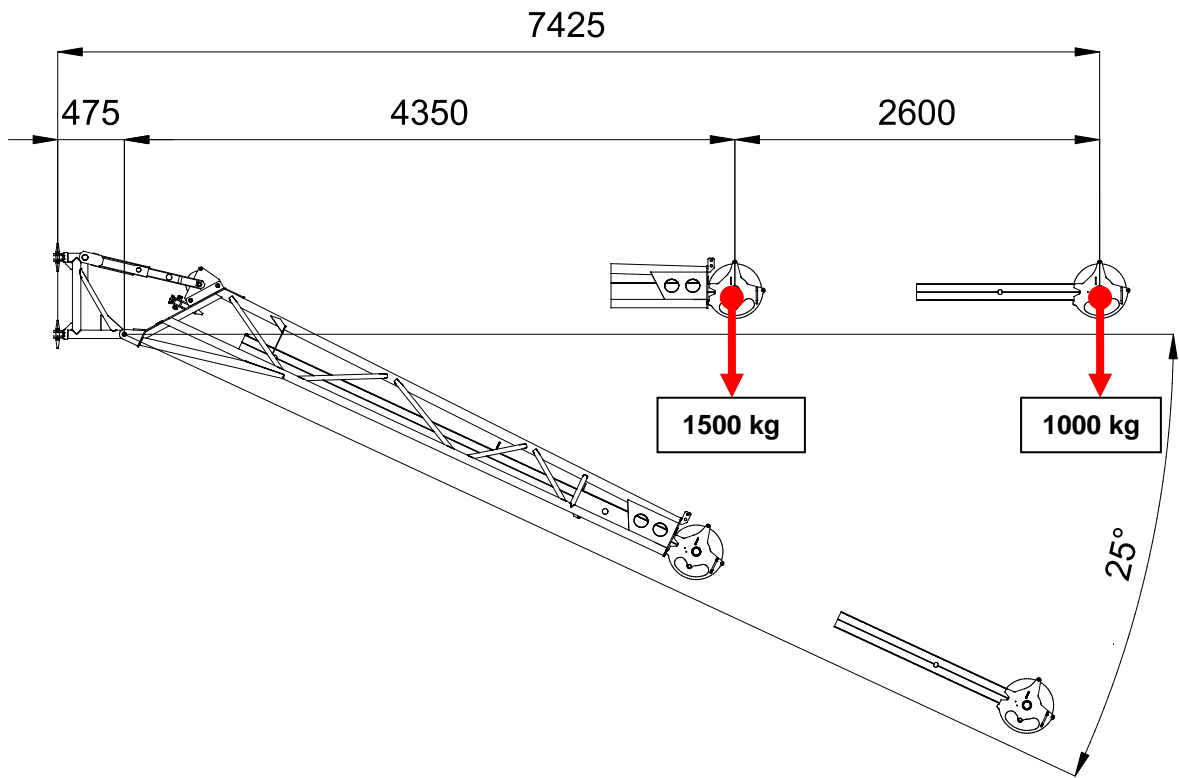

JIB1500.3HL

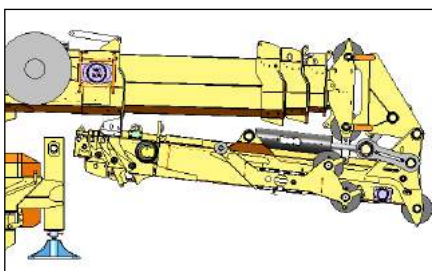
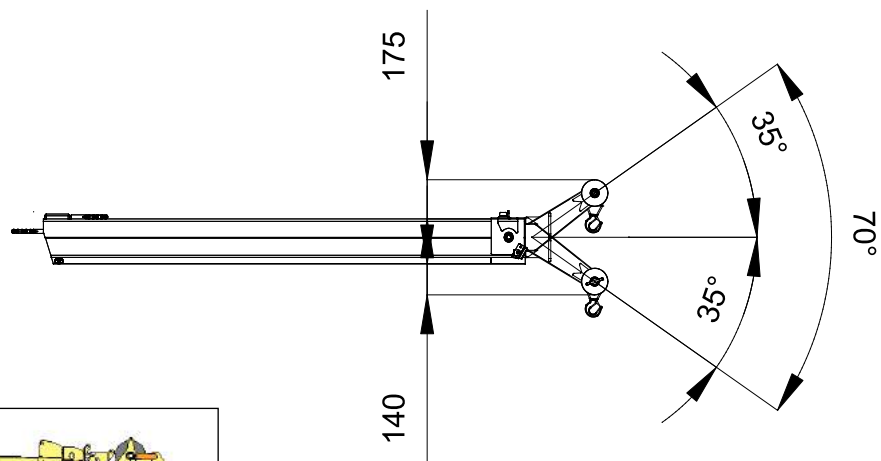
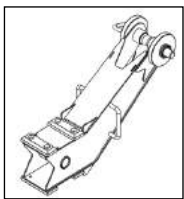
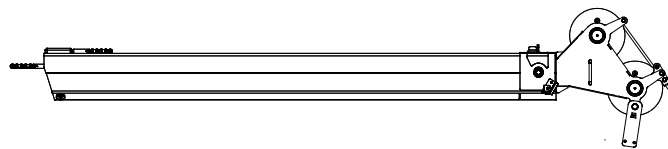
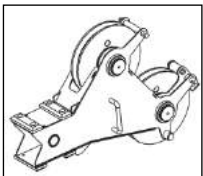
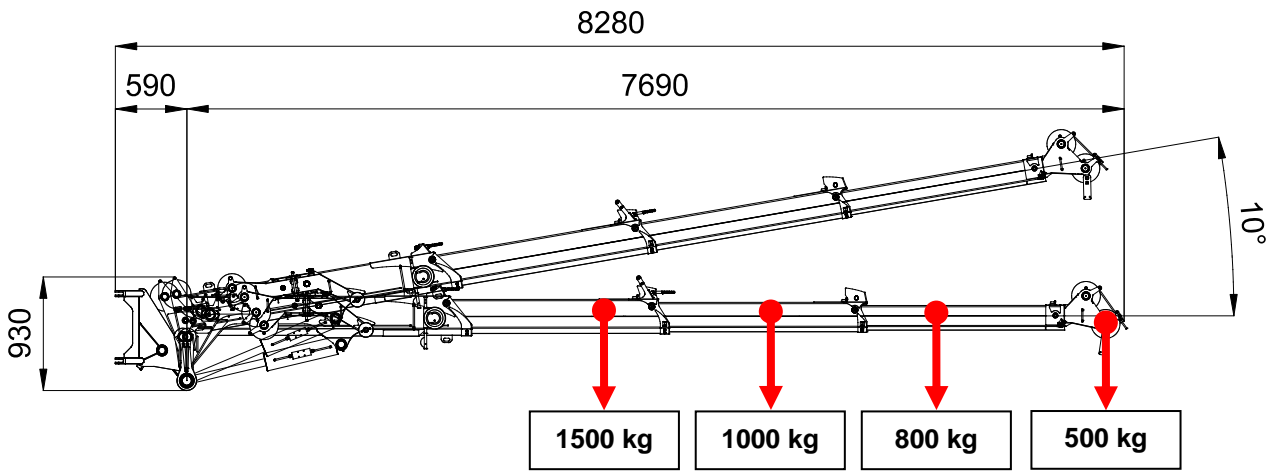
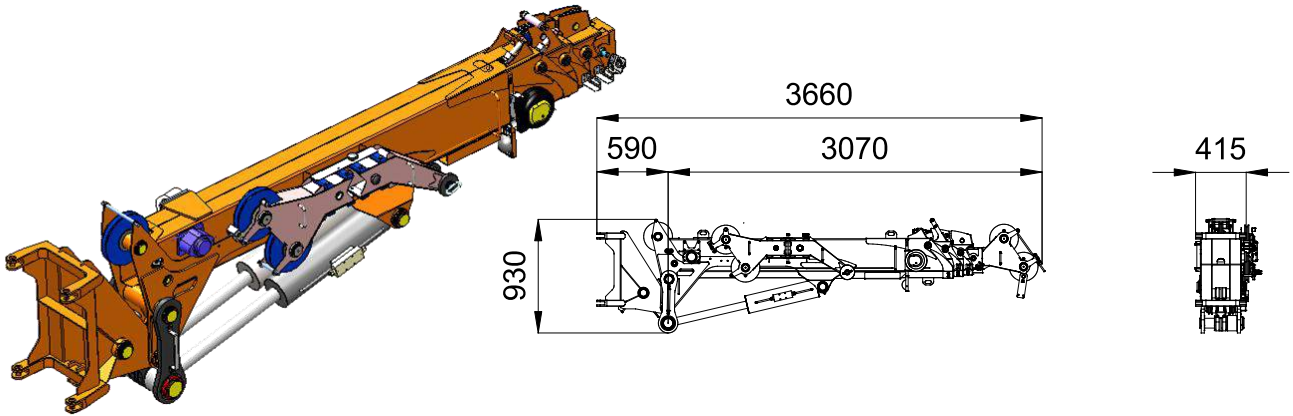

Fast out of service position

JIB300GR

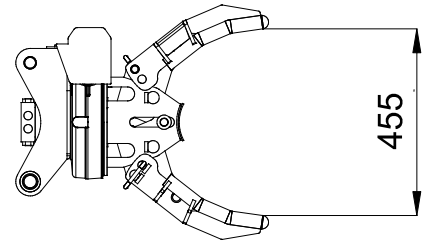
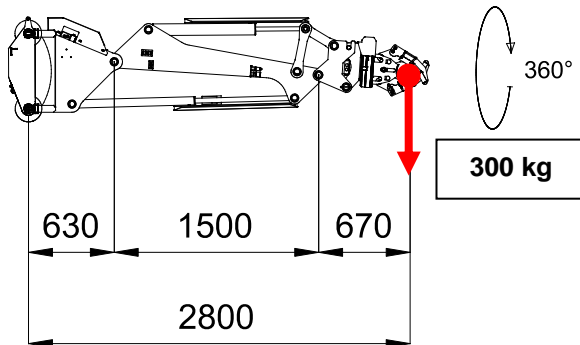
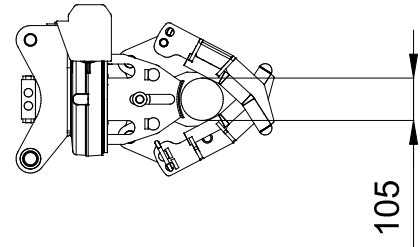
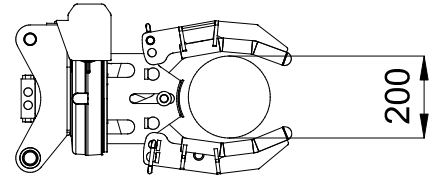
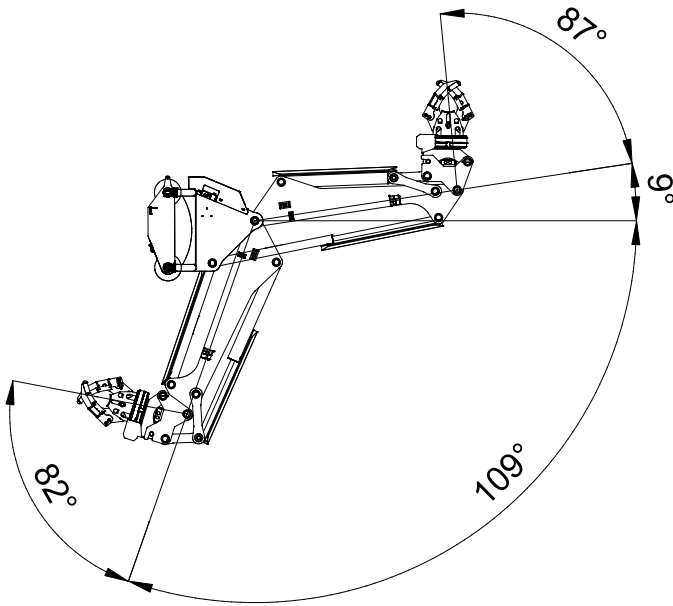

SYMBOLS

	Weight		Engine		Boom Angle		Minipicker
	Counterweight		Diesel Fuel		Boom Length		Back Wheel Loading Point
	Crane		Petrol Fuel		Boom Radius		Front Wheel Loading Point
	Dimensions		Tank		Jib on Board		Working Radius
	Stabilization Area		Power		Without Jib on Board		Stabilizing Bar
	Travel Speed		Battery		Jib Hook Radius		Standard
	Gradeability		Lithium Battery		Jib Length and Angle		Factory max. load
	Outrigger Load		Powerpack		Jib Length		Building site max. load
	Track Loading		Main Winch		Jib Radius		Maximum inclination of the machinery
	Outriggers Setup		Hookblock		Manipulator Length		Hydraulic oil
	Ext Tracks Width		Slewing		Manipulator Radius		Winter Warm-up Kit
	Chart on Tracks		Slewing Locked		Number of vacuum pads		Horizontal Boom Angle
	Slope		Outriggers mats		Grabber		White Pads for Steel Tracks

REMARKS REFERRING TO LOAD CHART

- The load charts are calculated according to EN 13000.
- For the calculation of the load charts at least a wind speed of 9m/s (33km/h) and regarding the load a sail area of 1m² per ton load and a wind resistance coefficient of 1.2 on the load have been taken into account. For lifting of loads with large sail areas and/or high wind resistance coefficients the maximum wind speed as stated in the load charts has to be reduced.
- Lifting capacities are given in kilograms.
- The weight of the hook blocks and hooks is part of the load and therefore it must be deducted from the lifting capacities.
- Working radii are measured from the slewing centre.
- The lifting capacities given for the telescopic boom apply if the folding jib is removed.
- Subject to modification of lifting capacities.



DEALER



JEKKO S.r.l. via Campardone, 1 Z.I. 31014 Colle Umberto (TV)
Italy tel. +39 0438 1710083 fax +39 0438 1710123
www.jekko.it - info@jekko.it